

THERMAE GRÖSSLING



MULTIFUNCTIONAL PUBLIC SPACE: "GRÖSSLING GARDEN"

The intention to revitalize the buildings of the former Grössling City Bath by integrating a multitude of functions is reminiscent of the notion of the ancient Roman thermae: these baths were used not only for hygienic purposes but also served as scenes for social and cultural activities. According to philosopher Henri Lefebvre, the Roman baths are the most successful architectural "spaces of enjoyment" that "remain for us an irreplaceable example of multifunctional architecture – polymorphous and polyvalent."¹

Multifunctionality is a key element of the development's programme, so in our proposal we seek to redefine this term from the perspective of future users. Our aim is to enhance the phenomenon of multifunctionality by turning it into a lived experience: thus functions brought together should not remain isolated from each other. We wanted to find the architectural means of making the simultaneous presence of various functions constantly perceivable at every part of the complex. The analogy of the Roman thermae offers inspiration to evoke this effect in spatial terms as well: gardens, generous roofless interiors, chains of interconnected spaces had been implemented that created the sense of openness, transparency and publicity. In order to experience the versatility of uses, we decided to "open up" the presently overbuilt block of the Grössling Bath by creating visual and functional connections with new openings in the interior – following the order of the original axes – and increasing the open-air areas significantly by both removing and reusing roof surfaces.

In addition to making new openings and open areas, we also used the spatial arrangement of the three functional parts of the complex as a tool to make the opportunities of their connections diverse. The three functional parts are a public space, a library and a bath. We composed the premises of all the three parts as three chains of versatile spaces: all the three "space chains" include interior and exterior areas, active and intimate zones, and points of encounter with the other two parts. In the following paragraphs the experience of the three functional parts are described one-by-one from the perspective of future visitors.

The chain of the public space part comprises of several areas: there is a park at Medená street, from where you can reach a terrace directly connected to the first floor of the former bank building's northern wing. The whole wing is transformed into a café, that has multiple accesses to a new garden occupying the middle of the Grössling block. This inner garden called "Grössling Garden" is the melting point of all the functions in the complex: from here people can access the library, users of the bath can enter this garden from the refurbished historic bathing pool located in the middle of it, and walkways on multiple levels can be seen connecting roof terraces. This is the most lively part of the complex: you can see people socializing, reading, or relaxing on sunbeds. From the garden you can enter into the preserved boiler house, where the hundred-year-old boiler can be observed. Through the windows of the boiler house another courtyard can be seen, however that is not accessible from here, since it is a private reading zone. From the boiler house one can enter into a small courtyard, where the old chimney of the bath is located. From here a passage can be reached inside a seven-storey building that leads to Vajnaského street. On the passage you can find a stairway that enables people to enter the roof of the building, where you can enjoy a beautiful panorama.

1ST FLOOR PLAN
courtyards
A: public Grössling Garden B: public park C: library courtyard D: bath courtyard
premises
1: entrance hall 2: stairway to the changing rooms 3: café and kids' zone 4: bar 5: toilets 6: café reading zone 7: café terrace 8: boiler house as public space 9: chimney courtyard 10: public passage 11: public stairway 12: library entrance hall with lockers 13: reception 14: toilets 15: interactive library zone (open 0-24) 16: stairway to library passage 17: entrance to the area with pools 18: passage 19: first aid 20: toilet 21: steam bath 22: Finnish sauna 23: changing rooms 24: preserved pools 25: swimming pool 26: reconstructed pool 27: sauna 28: steam bath 29: open-air pool 30: relax zone 31: changing rooms with showers and toilets of relax zone 32: reception of relax zone 33: entrance of relax zone

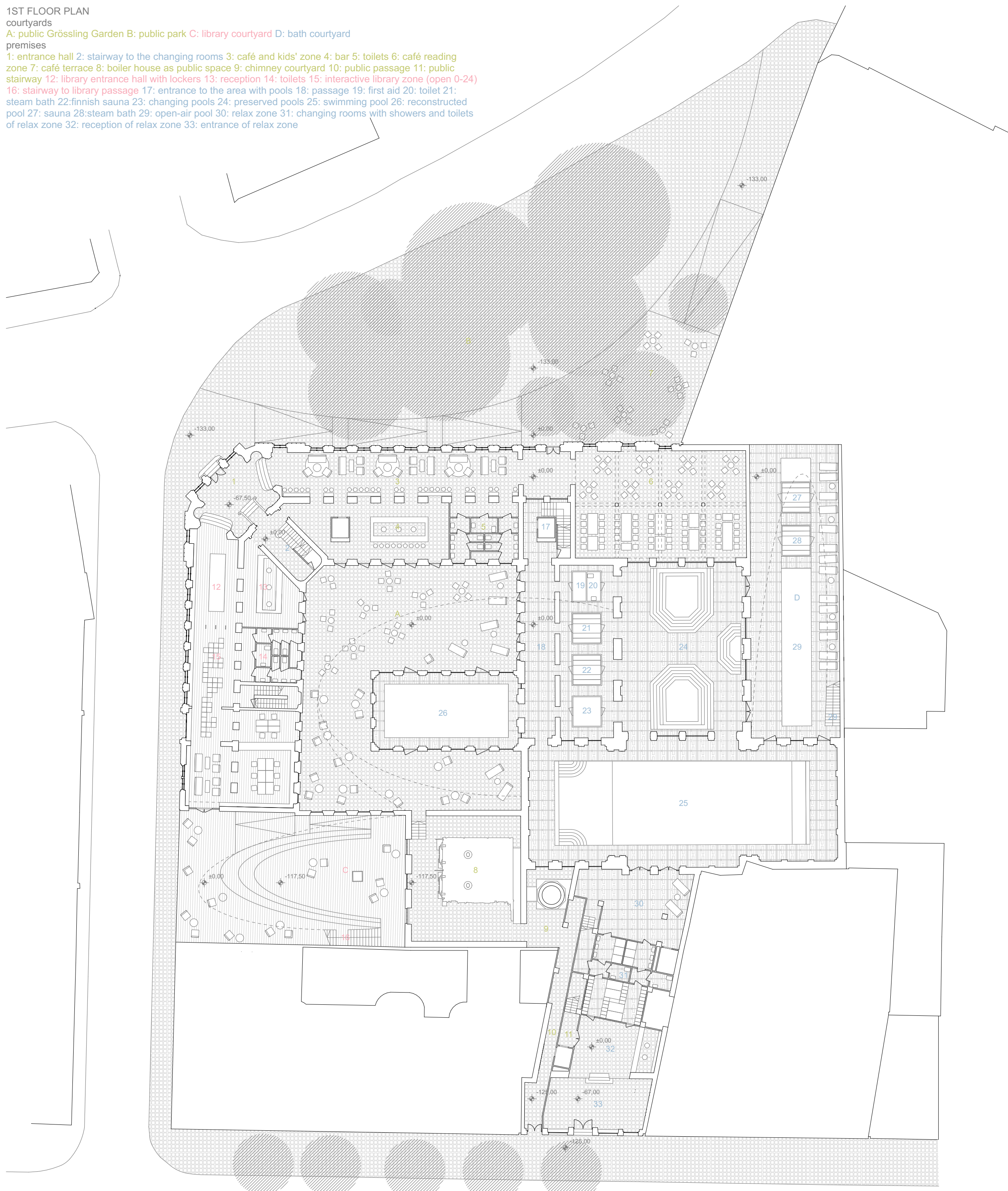

The second part is the library. People can enter the historic building of the bath at its main entrance located at the corner of Medená street and Kúpeľná street. In the restored entrance hall visitors can enter the interactive zone of the library placed on the first floor of the southern wing. From here one can enter "Grössling Garden" and if you walk through the floor you can visit a courtyard that is dedicated only for readers. This is a silent and intimate place framed by the facade of the boiler house from West. Here you can see an open-air stairway that leads to a passage at the second floor, at the end of which you can reach a roof terrace above Grössling Garden. Both from the pathway and the stairway located on the first floor you can enter the silent zone of the library that fills the whole second floor of the former bank building.

The third functional part is the most intimate one: the bath. From the main entrance hall people can use the stairway or the elevator to the third floor to reach the changing rooms. After changing clothes and having shower you descend to the first floor again but this time through another stairway. During your way downstairs you can see the interior of the library on the second floor and the café. From the first floor you enter the interactive zone of the bath: all the pools can be reached from a passage. At the end of the passage you reach the swimming pool that is connected to the relaxing part of the bath. That is located in four levels of a modernist building, the highest of which containing a roof terrace and a snack bar. This roof terrace is the starting point of an open-air pathway leading around the Grössling Garden in the middle of the block. From here you can see the public life of the whole complex. At the end of the pathway you reach another terrace for sunbathing. You can also continue your way from here through a stairway to a secret courtyard dedicated only for bath users. From this courtyard you can enter the interior bath premises again.

As the three descriptions show, the development is not simply three individual functions put next to each other, but much more: unconventional, unexpected and surprising encounters make time spent here a unique experience: you can read a book on a terrace while looking at people swimming and walking around wearing bathrobes. You can drink a coffee and have a talk with a friend of you in an intimate garden while you can see groups listening to a lecture, attending a workshop, while others are sunbathing. You can relax in a bath pool while observing the public life of a café. However, you can also exclude the whole outer world by entering a courtyard, where no one from outside can see you.

¹ Henri Lefebvre; Lukasz Stanek, editor; Robert Bononno, translator. *Toward an Architecture of Enjoyment*. Minneapolis: University of Minnesota Press, 2014, p. 138.

chain of public areas through the block

You can walk through the whole Grössling block via a chain of public spaces from North to South: the park of Medená street - café at the former bank building - Grössling garden - boiler house - courtyard of chimney - passage in the modernist building - Vajnaského street. This chain of areas constitutes a public passage, through which citizens can experience the versatile character of the development.

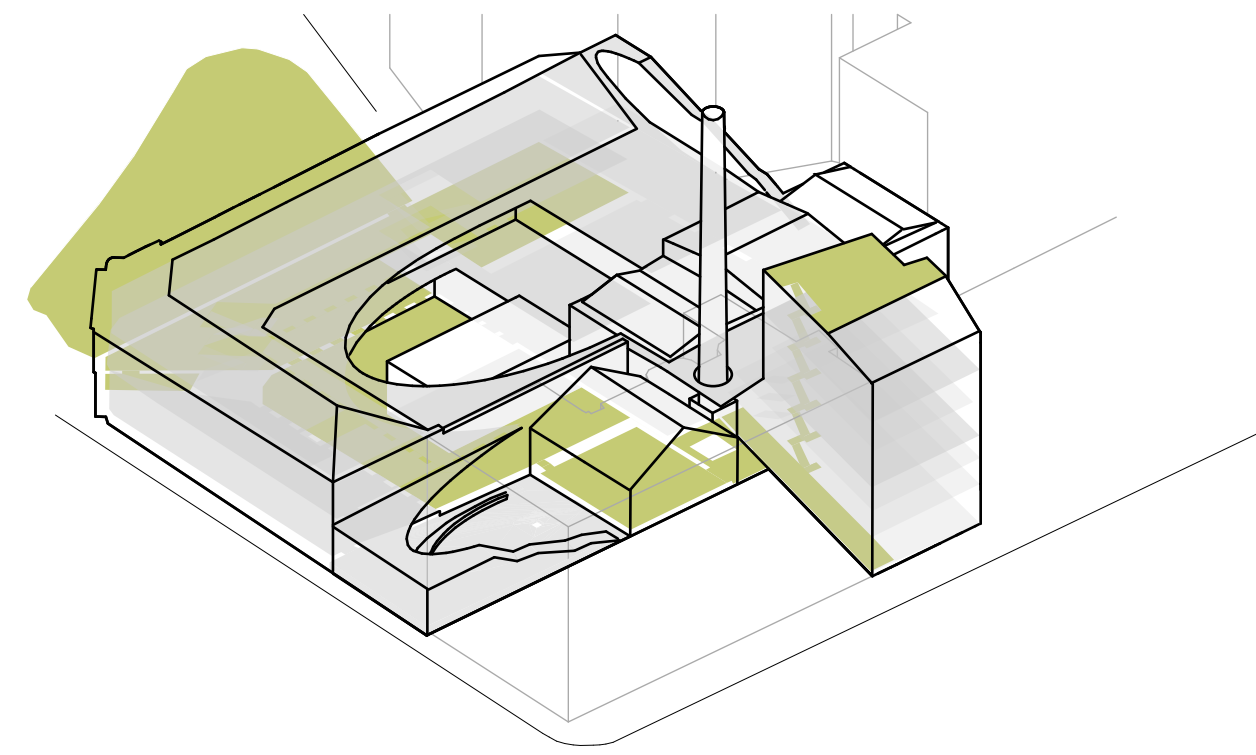

city library with open-air reading zones

The interactive zone of the library is located on the first floor of the southern wing of the former bank building. The rest of the interior spaces are located on the whole second floor. An exterior passage is located around Grössling Garden connecting a roof terrace on a courtyard on the southern part of the block dedicated only for library users. Apartments for the artist-in-residence programme are located on the sixth and seventh floors of the modernist building facing Vajnaského street.

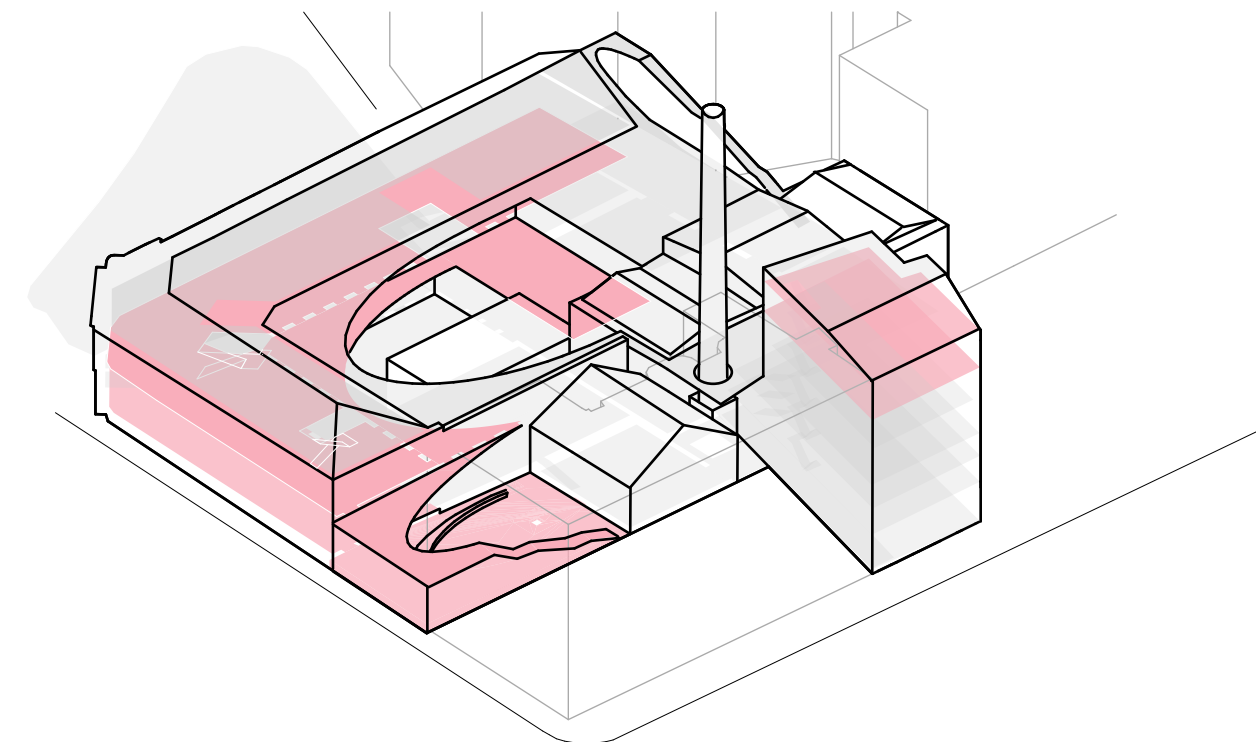

bath with route on the roofs

The main entrance of the bath is at the corner of Medená street and Kúpeľná street. Here a stairway leads to the third floor, where the changing rooms and the massage block is designated. The interactive part of the bath is reached on the first floor through another stairway. The relaxing zone can be reached from Vajnaského street. On the fourth floor of the modernist building there is a roof terrace from where another roof can be reached through a passage. A private bath courtyard is located at the eastern part of the block.

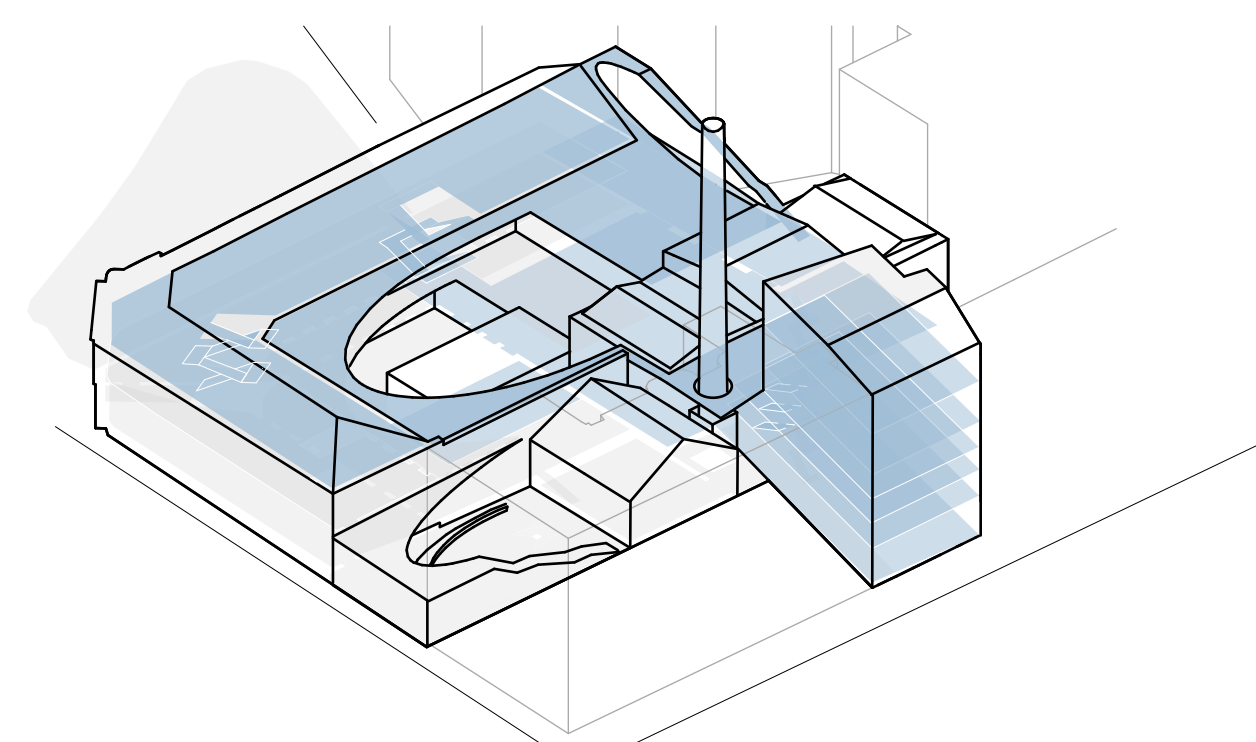

all three functions continuously perceived

All the open spaces of the development has different character: The public park at medená street is part of the city leading to the complex; the new Grössling Garden in the middle of the block can be used by all three functional parts of the complex. The courtyard in the southern part is a private one for library users, while the other on the eastern part is only for bath users.

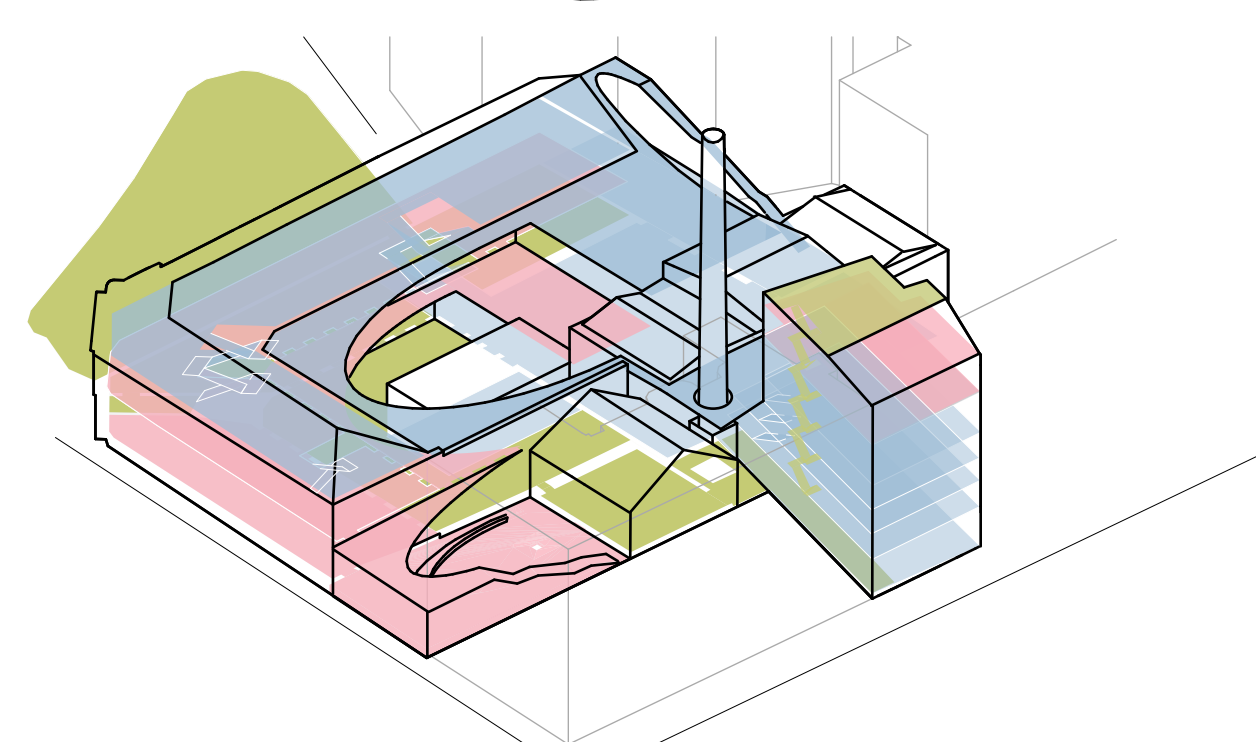

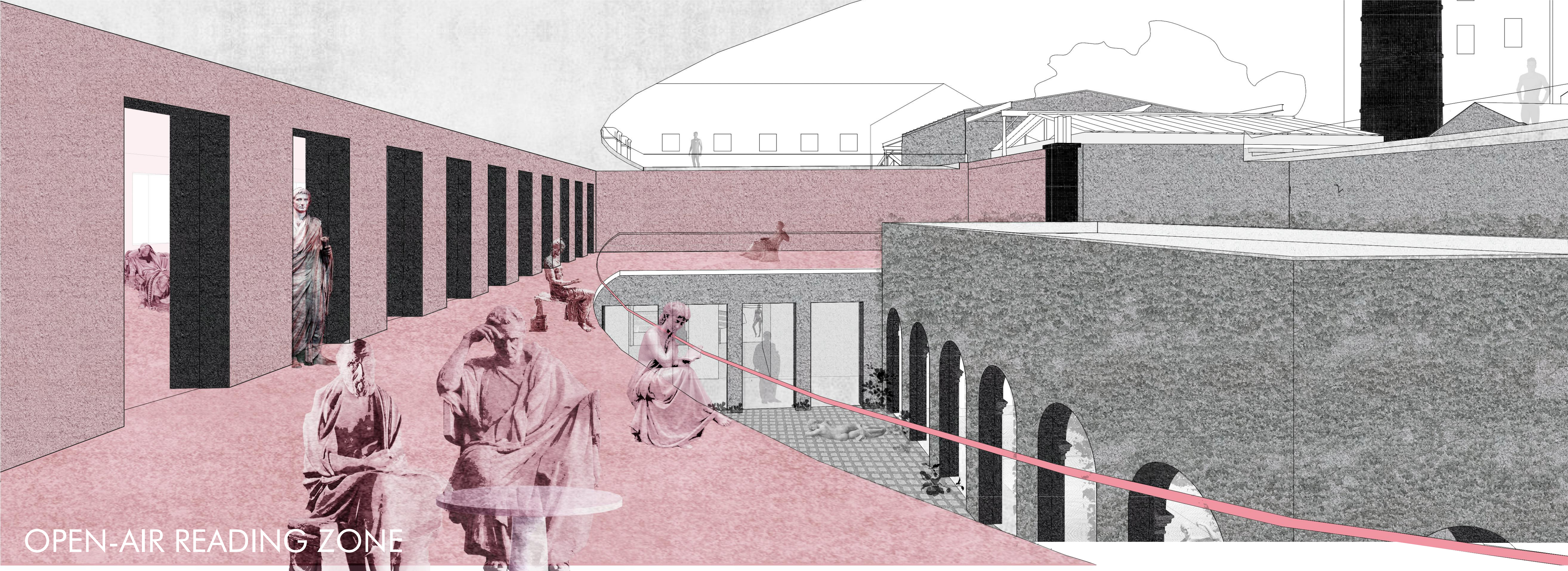

OPEN-AIR READING ZONE



BASEMENT FLOOR PLAN
 1: workshop 2: storage 3: garbage storage (bath) 4: maintenance staff social block 5: storage 6: garbage storage (bar) 7: storage and food preparation (bar) 8: bar staff social block 9-20: technical facilities 21-26: foyer 27-28: storage 29: garbage storage (bath)

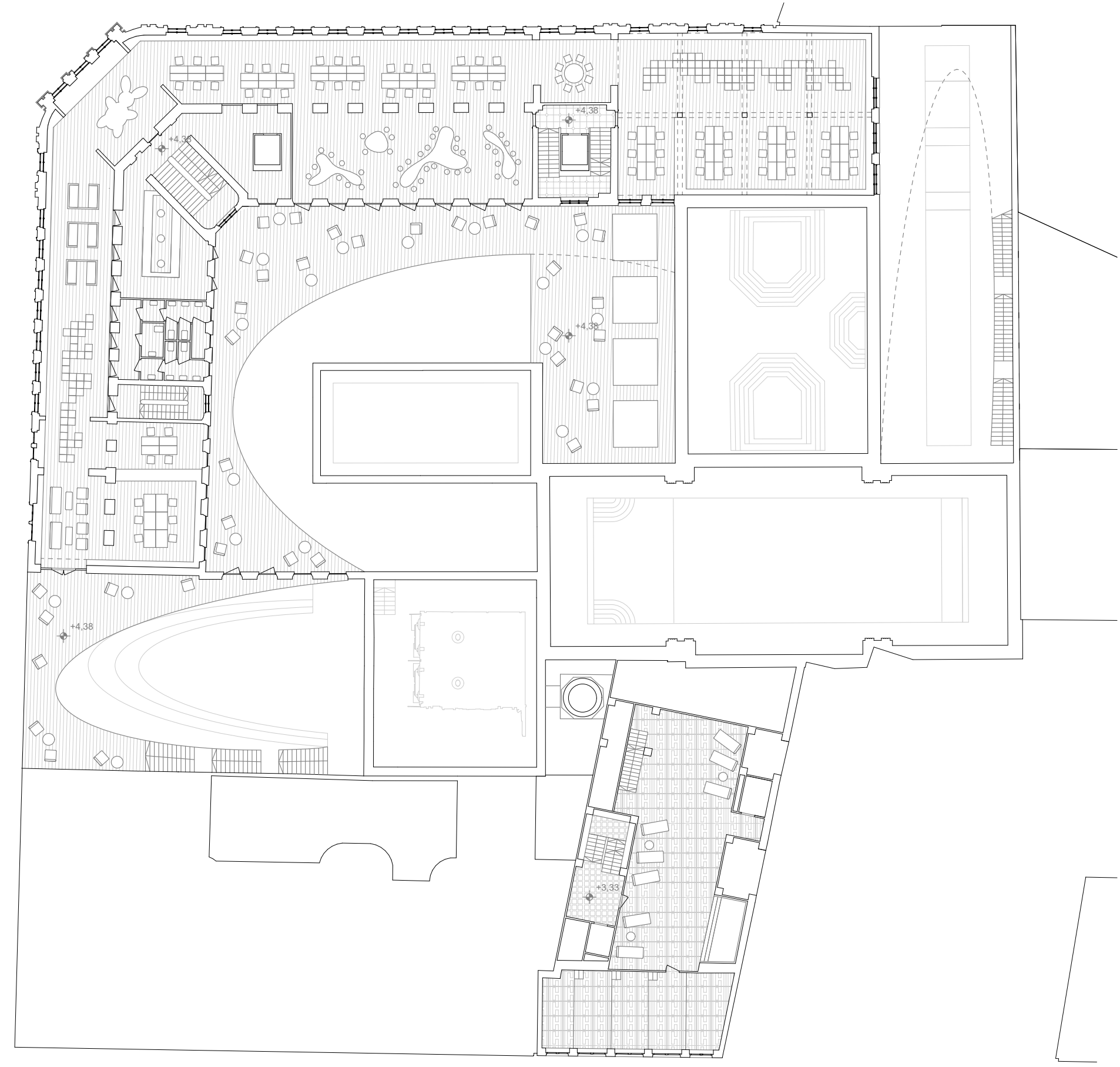

2ND FLOOR PLAN
 1: information 2: toilets 3: open shelves area 4: study area 5: office 6: workshop zone 7: open shelves area 8: study area 9: office 10: open-air passage 11: reading roof terrace 12: open-air passage to the library courtyard 13: stairway of the bath 14: changing pool 15: sauna 16: relax zone 17: public stairway

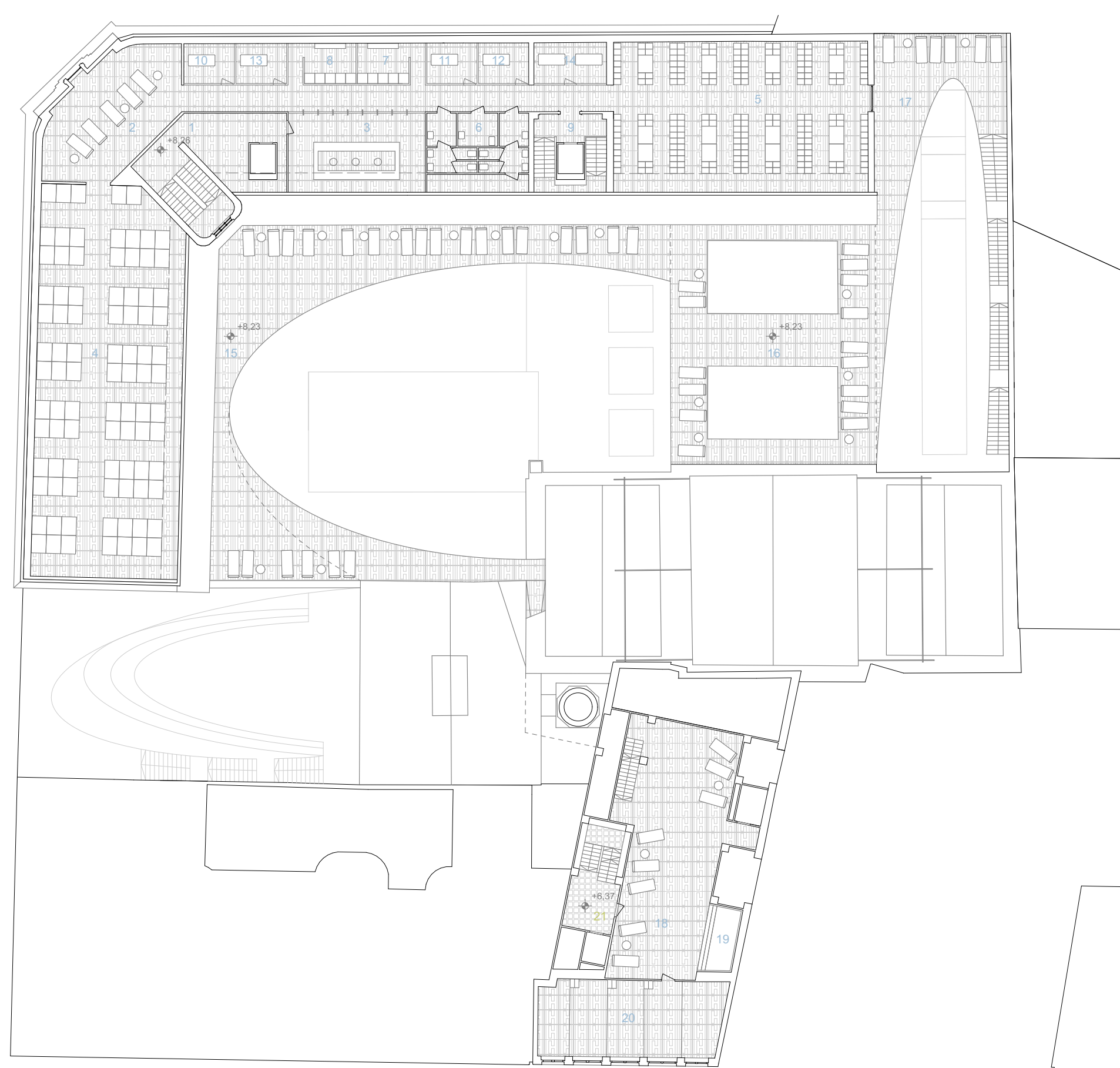

3RD FLOOR PLAN
 1: entrance to the changing rooms 2: hair drying and relax 3: reception 4: changing room with cabins 5: changing room with lockers 6: toilets 7-8: showers 9: stairway to the area with pools 10-14: massage and therapeutic rooms 15: open-air passage 16: roof terrace for relaxation 17: relax area and stairway to the bath courtyard 18: relax zone 19: changing pool 20: sauna 21: public stairway

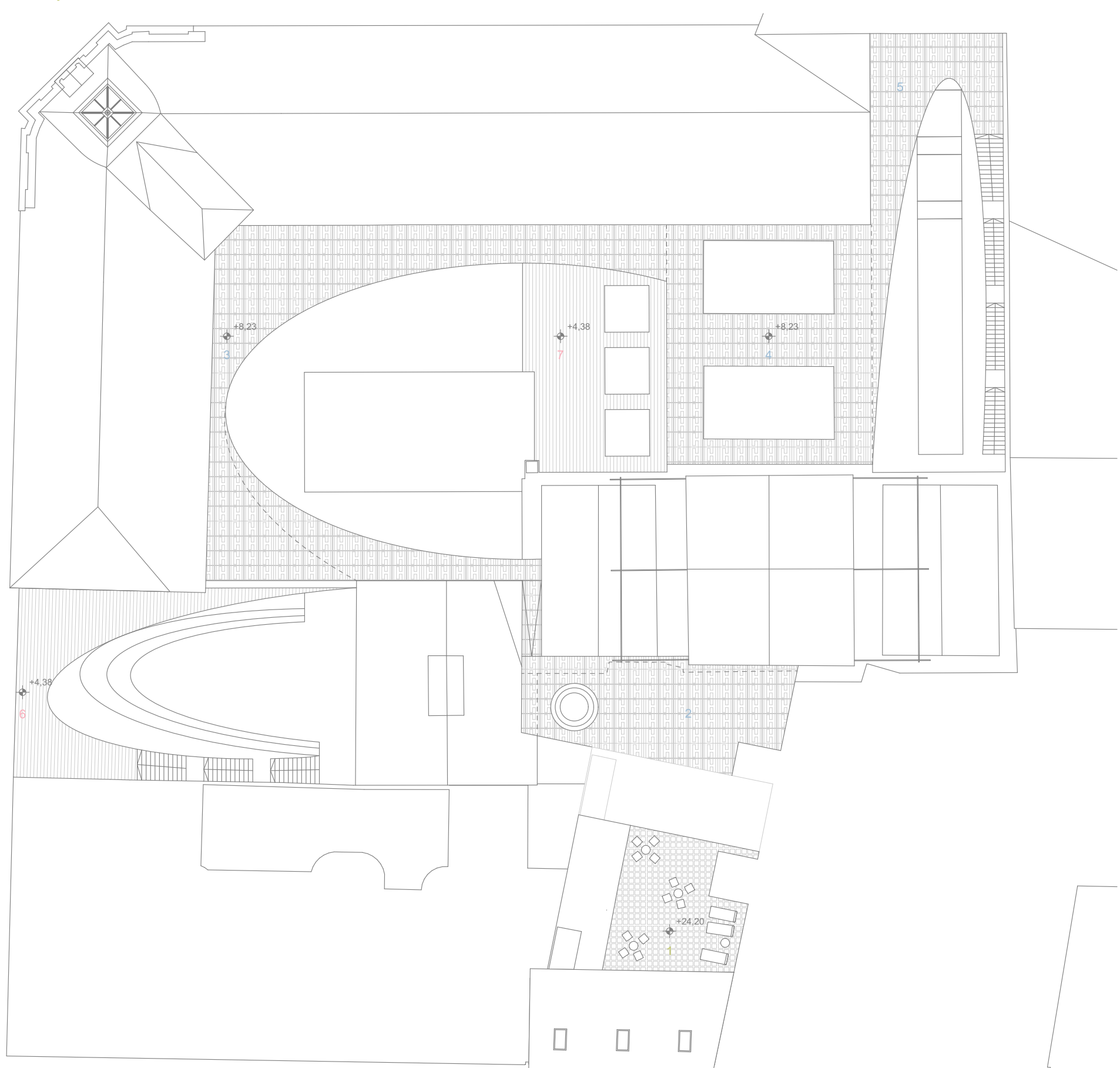

ROOF LEVEL PLAN
 1: public terrace 2: relax terrace 3: open-air passage 4: roof terrace for relaxation 5: relax area and stairway to the bath courtyard 6: open-air passage to the library courtyard 7: reading roof terrace

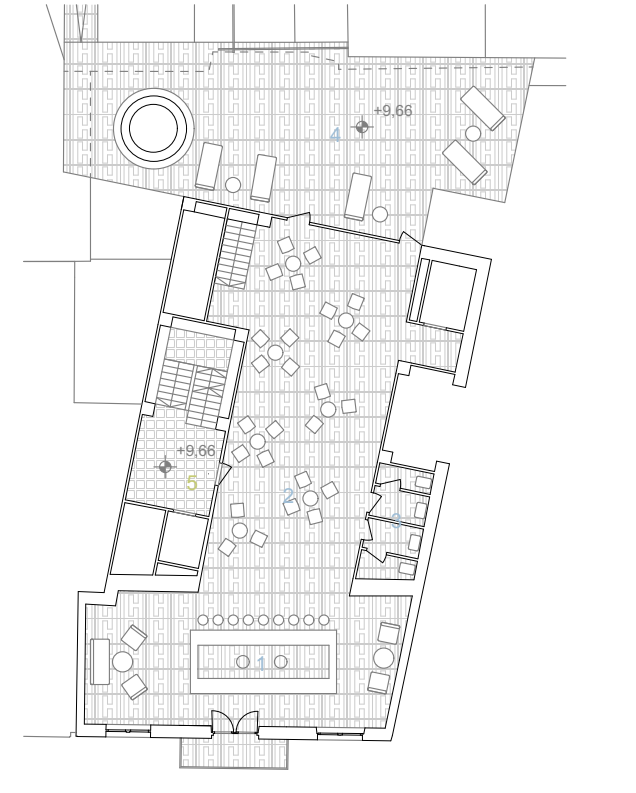

4TH FLOOR PLAN
 1: snack bar 2: relax lounge 3: toilets 4: relax terrace 5: public stairway



5TH FLOOR PLAN bath administration
 1: chilling area 2: bath staff changing rooms 3: toilets 4: laundry and storage 5: cleaning storage 6: office 7: office 8: meeting room 9: public stairway

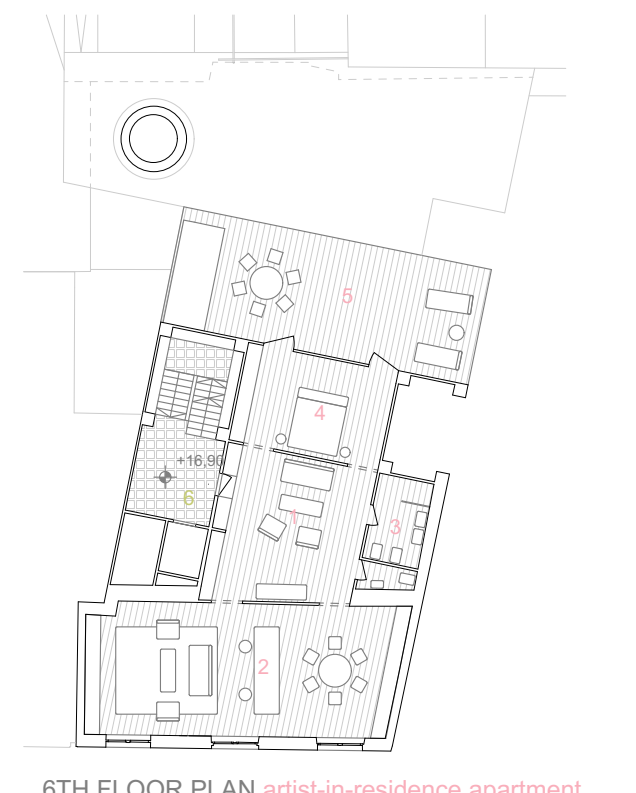

6TH FLOOR PLAN artist-in-residence apartment
 1: hall 2: working and living room 3: bathroom 4: bedroom 5: terrace 6: public stairway

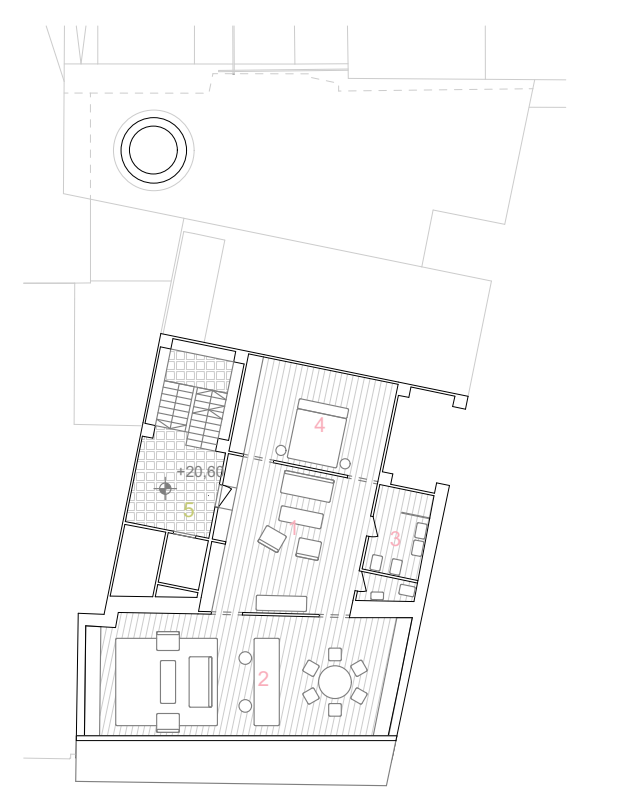

7TH FLOOR PLAN artist-in-residence apartment
 1: hall 2: working and living room 3: bathroom 4: bedroom 5: terrace 6: public stairway

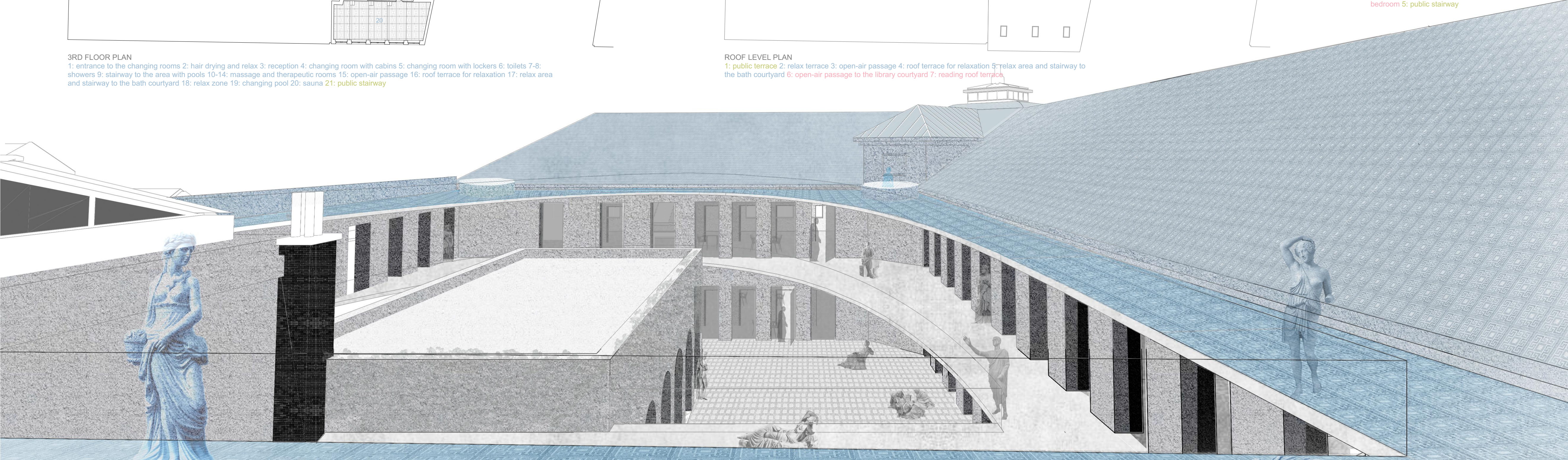

CITY BATH: CONNECTED ROOF TERRACES FOR RELAXATION